



Important Announcement

IPD Parts for Detroit™ Series 60® Engines

New Lower Pricing
More Inventory Availability

For pricing and availability, contact IPD or login into IPDNet™ today!



IPD PARTS ANNOUNCEMENT...

Detroit™ Series 60® Engines

News

Currently, IPD is planning to expand this product line to provide even better customer support. In preparation for these new expansion plans, IPD has lowered the pricing on current overhaul kits to be even more competitive in the marketplace, while increasing inventory to better respond to demand.

General Information

The Series 60 engine is an in-line 6 cylinder with wet replaceable liners, overhead cam and electronic engine control. These engines are mostly used in class 8 trucks, but can also be found in industrial and generator applications as well as occasional marine applications. IPD launched 16 Overhaul Kits, 4 Cylinder Kits, and many related components specifically for the 12.7L engine size applications in 2009.

Overhaul Kits

These kits feature IPD's Patented Cylinder Liner design with a special parabolic cooling groove that extends the effective volume of the cooling chamber higher on the cylinder liner, improving heat transfer between the liner and coolant at a most critical location.

Also, these kits feature two-piece articulated steel crown/aluminum skirt pistons, a design with which IPD has many years of experience and success.

Program Details

For current program details, please reference IPD's on-line Quick Reference listing for this product line ([click here for link](#)).

U.S. Patent #7334546

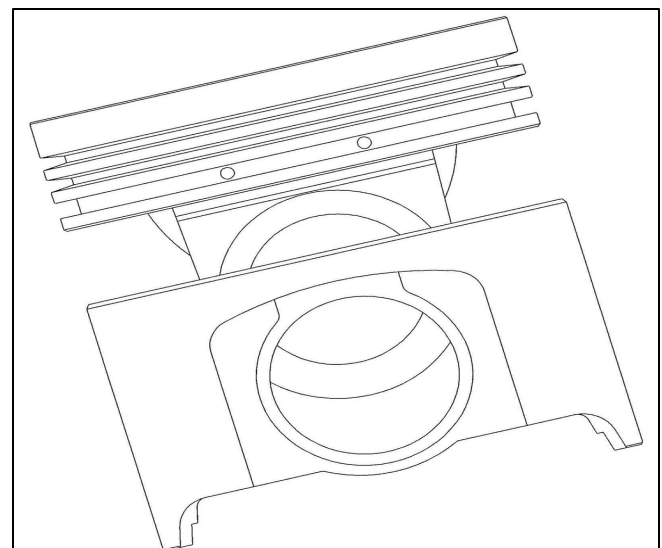

All manufacturers' names, numbers, symbols and descriptions are for reference only. It is not implied that any part is the product of the manufacturer. Detroit™, Detroit Diesel®, and Series 60® are trademarks of Detroit Diesel Corp.